

Build INTERIOR WALLS With Steel

Why Steel Studs?

Steel studs don't rot, warp, split, crack or creep. They don't burn or fuel the spread of a fire. They can't be consumed by termites and don't provide a home for various other pests and organisms. They are stronger, straighter, more dimensionally stable and more uniform in quality and performance. The price doesn't vary daily and you don't have to cut down 200 year old trees to build with them.

Plus, studs pre-drilled for plumbing and electric. There are no call-backs for nail pops or drywall cracks. Steel is 100% recyclable and studs use a minimum of 25% recycled material. Steel studs are lightweight and screwed (vs. nailed) so it's easy to build (and remodel) with steel. In short, steel studs build better homes and structures.

Steel Framing for Interior Walls

If you've never used steel studs before, interior non-loadbearing walls are the perfect place to start because they require no additional engineering, can be easily obtained at most major lumber yards, are easy to handle and install, and can be less expensive than other framing materials.

Before You Start

You can build your steel interior walls off-site and then raise them into position, or stick build in place. Either way, order the correct amount of materials by dividing the wall length by two, (if you're using 24-inch stud spacing) and add 20% for corner studs. You can order your wall track in 10-foot lengths. The quantities on your "cut list" are based on the length of wall, multiplied by two (for top and bottom track), with a 20% overage. You'll also need 2x6 stud and track materials for walls that hide plumbing risers and vents wider than 2-1/2" or 3-1/2" studs.

Get to know the Steel Stud Designators (the Right STUF-L: Stud, Track, U-Channel, Furring-Channel, and L-Header materials). This will greatly assist you in ordering the right materials for your project.

Typical steel studs used for interior walls include nomenclatures:

- 350S125-18: 3-1/2" width, Stud, 1-1/4" wide (flange), 18-mil (minimum base metal thickness)
- 350S125-33: same as above but thicker 33-mil material

Clear the floor area before doing the wall layout. Follow your drawings and measure the location for all the interior walls. Use your chalk line (see Tools & Fasteners) to layout the location of the walls, paying close attention to chase walls. Mark all locations for closet doors, other doors, and wall openings.

Maximum Allowable Clear Height for Fully-Braced Non-Load Bearing Wall Studs

Member Size	Stud Spacing	Clear Height
350S125-18	16"	9'10"
	24"	6'6"
350S125-33	16"	17'0"
	24"	14'10"

Basic Steel Framing Stud & Track Details

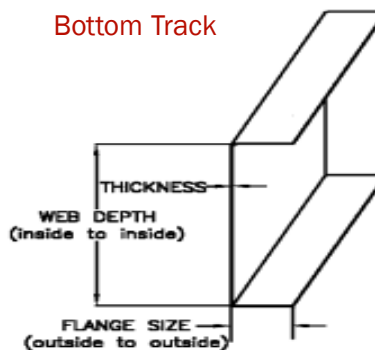
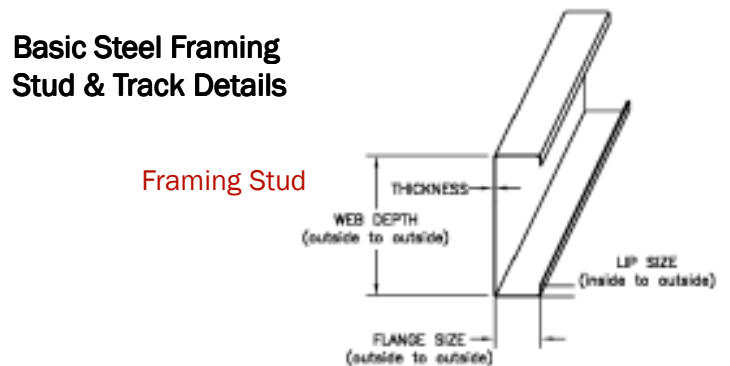

Track Connection

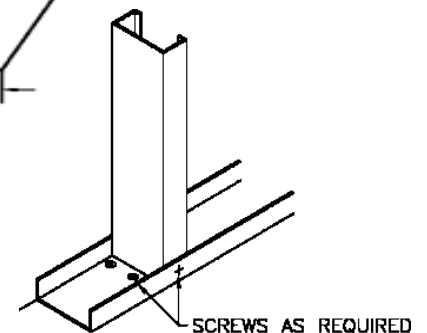

Tools & Fasteners

- Adjustable torque/clutch screw gun, 0-2500 rpm, variable speed, reversible, bit tip holder release
- Swivel head electric shears
- Four-foot magnetic level, plumb bob, and a chalk line (black chalk works well on steel)
- 3-inch and 6-inch locking C-clamps with regular tips
- No. 6 sharp point, bugle head screws (drywall screws)

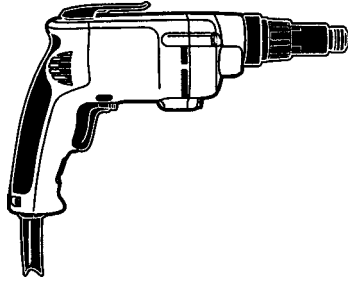

Self-piercing tip



Others include:

- Aviation snips
- 5/16-inch magnetic hex driver
- No. 2 Phillips bit tips
- Hand seamers for bending and coping tracks
- 2-inch magnetic bit tip holder
- Felt markers for layout and cuts
- Speed square and tape measure
- Extension cords
- Gloves, tool pouch, hammer
- Utility knife
- Safety goggles or glasses

Installation Guide

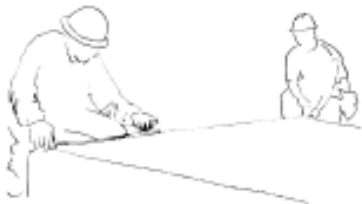

STEP 1 LAYOUT:

Use a chalk line to layout the location of the walls on the floor.

STEP 2 CUT TRACK:

Cut the top track the complete length of the wall (splice tracks where necessary). Cut the bottom track and cut out track pieces where door openings will occur.



STEP 3 MARK TRACK: Lay the top and bottom tracks next to each other in place (on the chalked line) and mark the stud locations.

Tip: The layout will be faster and more accurate if the top and bottom tracks are marked at the same time. Use a black felt tip marker to mark the location of the layout studs.

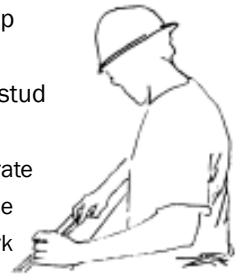

STEP 4 ATTACH TOP TRACK:

Mark the location of the wall on the ceiling structure above using your chalk line, then attach the top track to the ceiling using the appropriate connector for the specific ceiling framing materials (typically 24 inches on center).

Tip: Use blocking where the top track is parallel to floor joists (as shown below).

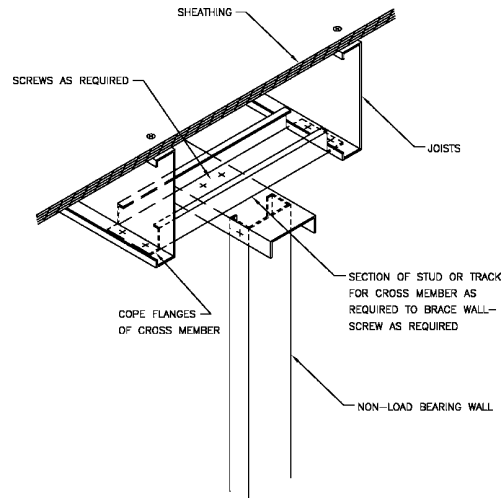

STEP 5 PLUMB:

Use your plumb bob to layout the location of the walls on the floor.

STEP 6 ATTACH FLOOR TRACK:

Connect the bottom track to the floor with the door openings already cut out. Screw the track to the wood subfloor (typically 24 inches on center), or fasten the track to the concrete slab (typically 24 inches on center) with powder actuated fasteners.

STEP 7 INSERT STUDS:

Twist the studs into the track on layout, with flanges facing same direction and openings matched up.

Tip: Use two studs adjacent to all openings.



STEP 9 ATTACH STUD TO TRACK:



Screw stud to top and bottom track with screws, holding flange to track for easier attachment.

Tip: Use the magnetic level to ensure that all studs are plumb.

STEP 10 ATTACH CABINET BLOCKING:

Screw notched C-shape cross bracing (blocking) for hanging cabinets, railings, or where any heavy objects will be attached.

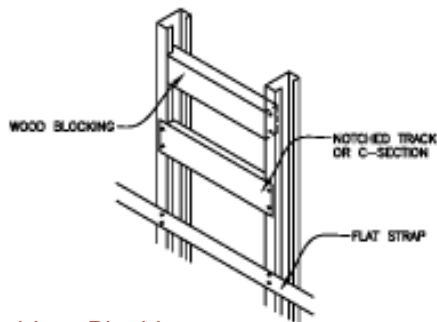

Cabinet Blocking

STEP 11 INSERT GROMMETS:

Insert plastic grommets in pre-punched holes for wherever you pass through wiring and/or plumbing.

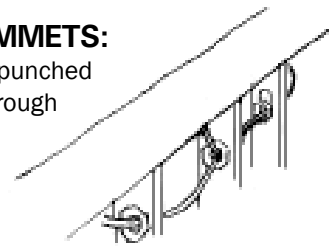

STEP 12 ATTACH GYPSUM:

Fasten gypsum wall to steel studs with drywall framing screws (typically 12 inches on center).

Tip: Board should be attached advancing toward the open end of the studs.

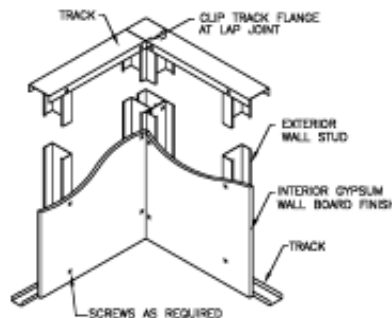
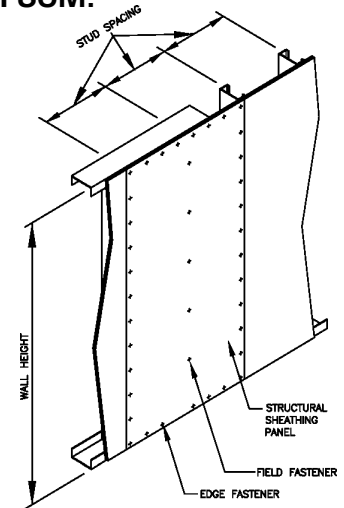

Corner Framing

CONSTRUCTION & SAFETY TIPS

- To attach trim, use adhesives first to set placement and then screw as required. You can also insert 2x4 wood blocks inside track to nail trim.
- Some door and window installers prefer wood 2x4 blocks around the rough opening to hang and secure doors and windows.
- Order insulation to the full 16" or 24" width dimension as required.
- Use C-shape blocking for hanging other heavy objects on the walls, similar to cabinets.
- Always wear protective gear when building with cold-formed steel framing members; safety goggles or glasses and leather-palm gloves are useful.

The materials set forth herein are for general information only. They are not a substitute for competent professional assistance. Anyone making use of the information set forth herein does so at his or her own risk and assumes

MORE RESOURCES

A complete guide to build interior walls with steel, including expanded details and tables, titled "Steel Wall Guide" is available through the Steel Framing Alliance at www.steel framingalliance.com or by calling (202) 785-2022.

Hybrid Construction

You may also want to resource construction details now available for steel-to-wood and steel-to-ICF hybrid construction. Visit Steel Framing Alliance, www.steel framingalliance.com, or the Steel Stud Manufacturers Association, www.ssma.com, or the Insulated Concrete Forms Association, www.icfa.org.

any resulting liability. Contact your Steel Framing Alliance member for the best products, best practices, and helpful service.

Copyright © 2004. All rights reserved.