

TECHNICAL NOTES



Bracing Webs in Trusses that have Dissimilar Configurations

Released April 25, 2006

Issue:

Truss Design Drawings (TDD) that are prepared in accordance with ANSI/TPI 1, *National Design Standard for Metal Plate Connected Wood Truss Construction*, provide information as to which web members in the truss require bracing in order to support their full design load. This includes the approximate location where lateral restraint (LR) (also known as continuous lateral bracing (CLB)) is to be attached, and may also include the type of material to be used. Due to the complexity of today's roofs, the "typical" roof truss package often includes so many different truss configurations that, in many instances, there may not be two adjacent trusses in which the webs align. In these instances, it is impractical, if not impossible, to apply continuous lateral restraint. The question often being asked is how to "brace" the web members that require lateral restraint when they don't align with similar webs in adjacent trusses?

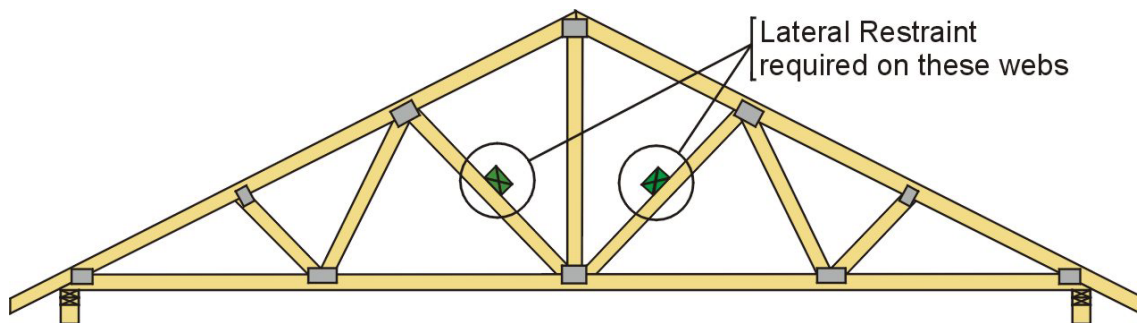

Figure 1

Key Definitions:

Building Designer – The owner of the building or the individual or organization (including either an architect, engineer or the contractor) that contracts with the owner for the design of the building structural system and/or who produces the structural design documents.

Diagonal Bracing – Used in conjunction with lateral restraint to transfer the forces accumulated in the LR into the supporting structure. Diagonal bracing is installed in the same plane as the LR but at approximately a 45° angle to the LR.

Lateral Restraint (LR) – Members installed at right angles to a chord or web member of a truss to provide stability to the truss. Also referred to as continuous lateral brace or lateral brace.

Registered Design Professional – An individual who is registered or licensed to practice their respective design profession as defined by the statutory requirements of the professional registration laws of the state or jurisdiction in which the project is to be constructed.

View all WTCA Tech Notes at www.sbcindustry.com/kb/technotes.php

WTCA • 6300 Enterprise Lane • Madison, WI 53719
608/274-4849 • 608/274-3329 (fax) • www.sbcindustry.com

T-DissimilarWebs06

Truss Design Drawing – The written, graphic and pictorial depiction of an individual truss.

Web Reinforcement – A piece of stress-rated lumber or a proprietary metal shape attached to the web as reinforcement to prevent buckling. Commonly used types of lumber web reinforcement include, T-bracing, L-bracing and scab bracing.

Background:

Trusses are intended and designed to support loads applied within their plane and transfer these loads to the bearings. Because trusses are relatively narrow in relation to their depth and span, they must be restrained laterally. Without this restraint, the entire truss, or a portion of its members, will buckle at loads far less than what they were intended to support. Lateral restraint is typically provided to the top and bottom chords by attaching wood structural panel sheathing, lumber purlins or gypsum board panels directly to these members. Certain web members must also be restrained in order to resist their intended forces. The bracing of these web members can be accomplished in a variety of ways.

Analysis:

Not all web members require restraint. Whether or not a web member needs to be restrained laterally depends upon many factors including the magnitude and direction of the forces it must resist and the size, length, species and grade of the lumber used. The Truss Design Drawing will indicate which webs require lateral restraining and the type and approximate location of the restraint or reinforcement.

BCSI-B3 Web Member Permanent Bracing/Web Reinforcement, a publication jointly produced by WTCA and the Truss Plate Institute (TPI), provides general industry recommendations and methods for restraining web members against buckling. This is accomplished by either reducing the buckling length (i.e., the span) of the web member via LR, or by reinforcing the member with additional material, thereby increasing its cross-section (i.e., T-bracing, L-bracing, scab bracing, etc.). Additional information on web member lateral restraint and individual web reinforcement methods can be found at www.sbcindustry.com/pubs/B3WEB-D. Standard details for bracing individual truss web members may also be available from the Truss Designer.

As long as there are at least two adjacent trusses with the same or similar web configurations, LR methods can be used. If a piece of lumber or board is to be used as the LR, a diagonal brace must also be installed at periodic intervals to resist the restraining forces in the LR and transfer these forces to the roof and ceiling diaphragms. Without the diagonal bracing, the webs connected by the LR are still prone to buckle together as a unit. For long continuous runs of LRs, diagonal bracing should be installed at no more than 20-ft intervals, unless a closer spacing is specified by the Registered Design Professional/Building Designer.

Figure 2 illustrates the lateral restraint concept used with small groups of trusses. In this simple example, the building contains nine trusses with three different configurations. Each truss configuration contains web members that require restraint and these web members are in different locations for each configuration. To ensure the webs of these trusses are properly restrained, install LRs (*shown in green*) and diagonal bracing (*shown in red*) within each group of trusses. Note that the diagonal bracing must extend from the top chord of the first truss to the bottom chord of the third truss and be attached to the web of the middle truss near the location of the LR. This provides the rigidity that prevents the webs and the LR from displacing laterally.

For groups of two trusses, the diagonal brace must be attached to each web and the LR. One way to accomplish this is to install dimension lumber blocking between the webs directly behind the LR. Attach the blocking to the LR and the diagonal brace to the blocking.

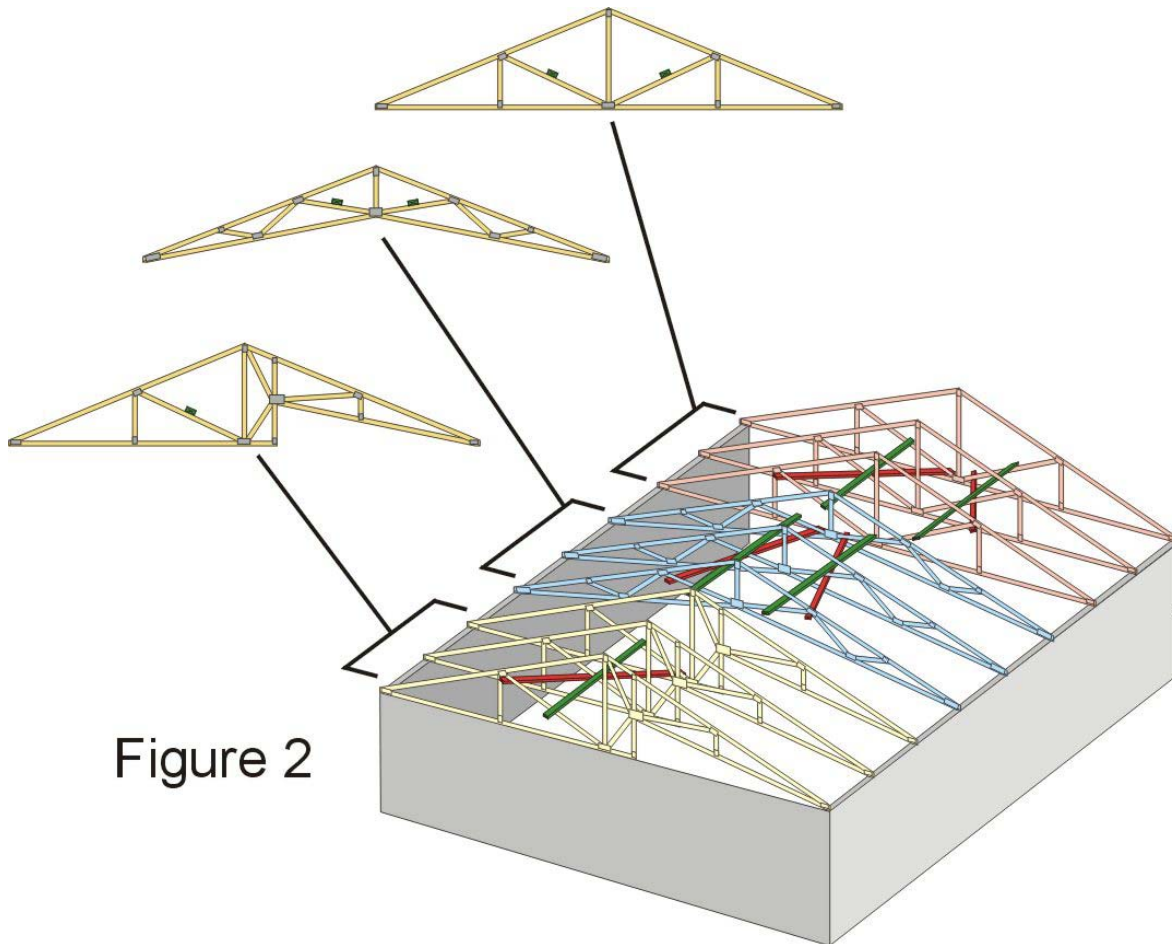

Figure 2

When there is only one truss that requires lateral restraint, a single diagonal without a LR may be used to brace the web by attaching the diagonal near the mid-span of the web. The ends of the diagonal must be cut to fit snugly against the top and bottom chords of the adjacent trusses and toe-nailed to each (see Figure 3).

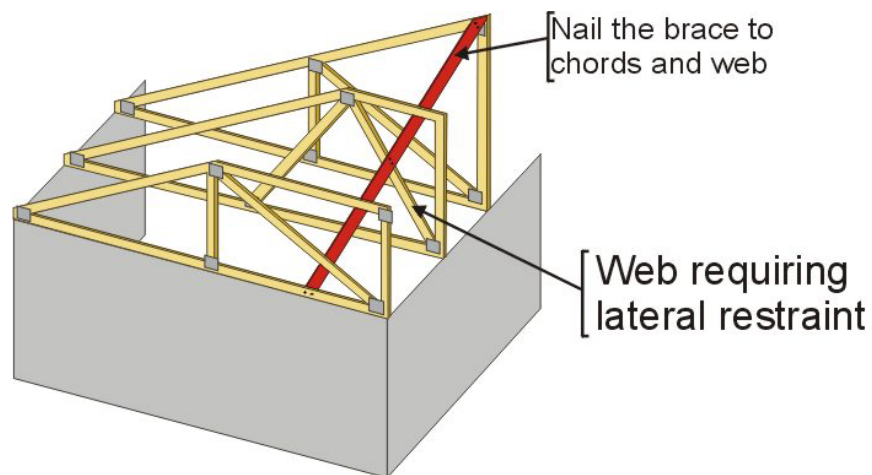

Figure 3

Another way to provide restraint to web members is to “reinforce” them by attaching an additional piece of lumber to increase the cross section and thereby, the resistance to buckling (see Figure 4).

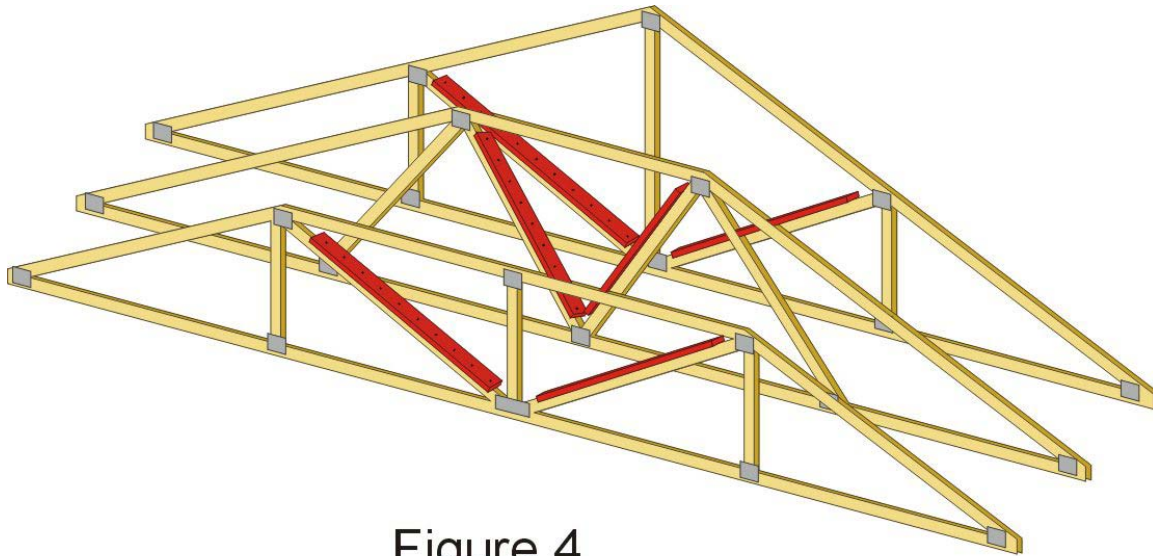

Figure 4

Web reinforcement is typically used when the webs requiring bracing do not align between adjacent trusses, but can also be used as an alternative to the lateral restraint method described above. The reinforcement can be added to the edge of the web to form a “T-” or “L-brace”, added to the face (i.e., scab), or installed in the manufacturing plant such as with proprietary metal reinforcement or “stacked” webs (see Figure 5).

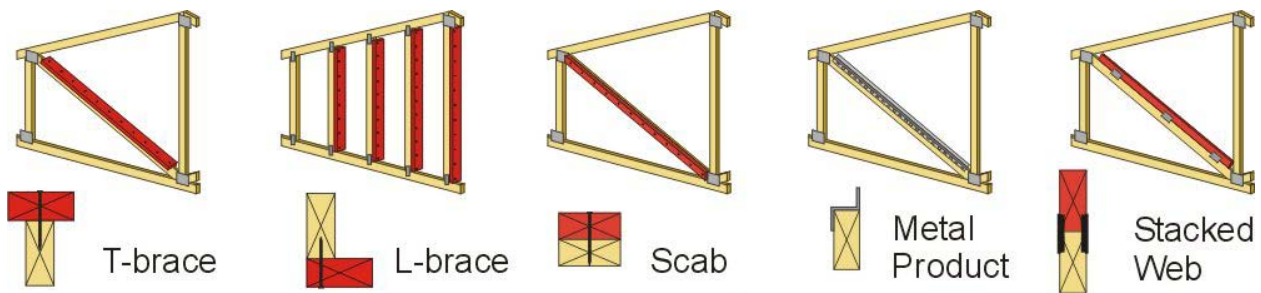

Figure 5

When two or more LRs are required for the same web, it is generally more efficient to use web reinforcement methods such as a T- or L-brace. Also, in order for the LRs and diagonal bracing to be effective, the top and bottom chords of the trusses must be adequately restrained. If the bottom chords of the trusses are not restrained laterally by a ceiling diaphragm or lateral and diagonal bracing within the bottom chord plane, it may be more cost effective to restrain the webs with individual web reinforcement.

Building Code Requirements

Section 2303.4 of the 2006 IBC (see Appendix A) provides new language on truss bracing that is intended to help ensure that web member stability is considered as follows:

2303.4 Trusses.....

2303.4.1.2 Truss design drawings.....

18. Required permanent individual truss member bracing and method per Section 2303.4.1.5, unless a specific truss member permanent bracing plan for the roof or floor structural system is provided by a registered design professional.....

2303.4.1.5 Truss member permanent bracing. Where permanent bracing of truss members is required on the truss design drawings, it shall be accomplished by one of the following methods:

1. The trusses shall be designed so that the buckling of any individual truss member can be resisted internally by the structure (e.g., buckling member T-bracing, L-bracing, etc.) of the individual truss. The truss individual member buckling reinforcement shall be installed as shown on the truss design drawing or on supplemental truss member buckling reinforcement diagrams provided by the truss designer.
2. Permanent bracing shall be installed using standard industry bracing details that conform with generally accepted engineering practice. Individual truss member continuous lateral bracing location(s) shall be shown on the truss design drawing.

2303.4.1.6 Anchorage. All transfer of loads and anchorage of each truss to the supporting structure is the responsibility of the registered design professional.

The code therefore requires:

1. A specific truss member (i.e., chord & web) permanent bracing plan for the roof or floor structural system provided by a registered design professional, or
2. Individual web reinforcement to increase the cross section and thereby, the resistance to buckling as described above and in *BCSI-B3*, or
3. Providing lateral restraint (i.e., LRs and diagonal bracing) to the web members and at the locations shown on the truss design drawing, so that the group of webs so braced remains stable.

Finally, the flow of load through the bracing into the roof, floor and/or ceiling diaphragms or other load resisting elements is the responsibility of the Registered Design Professional and/or Building Designer.

Conclusion:

There are several options available for stabilizing the truss web members from buckling. Continuous lateral restraint in combination with diagonal bracing is very common; however, there are many instances in which this may not be practical. For these cases, individual web reinforcement offers the best option. Consult with the Truss Designer during review of the Truss Design Drawings.

The Truss Manufacturer is responsible for providing Truss Design Drawings that show which members need to be restrained to prevent buckling, as well as the approximate location where the restraint needs to be attached. The contractor is responsible for installing the restraint in accordance with a specific truss member permanent bracing plan for the roof or floor structural system as provided by the Registered Design Professional, or in the absence of such information, through the use of individual web reinforcement or lateral restraint and diagonal bracing as described above and in *BCSI-B3*. The Registered Design Professional and/or Building Designer is responsible for ensuring that the LR is adequately stabilized using diagonal bracing or some other means and for providing a load resisting element (e.g., diaphragm) capable of resisting the forces from the diagonal bracing.

Appendix A

2006 International Building Code

Chapter 23 WOOD

SECTION 2303: MINIMUM STANDARDS AND QUALITY

2303.4 Trusses.

2303.4.1 Design. Wood trusses shall be designed in accordance with the provisions of this code and accepted engineering practice. Members are permitted to be joined by nails, glue, bolts, timber connectors, metal connector plates or other approved framing devices.

2303.4.1.1 Truss designer. The individual or organization responsible for the design of trusses.

2303.4.1.2 Truss design drawings. The written, graphic and pictorial depiction of each individual truss shall be provided to the building official and approved prior to installation. Truss design drawings shall also be provided with the shipment of trusses delivered to the job site. Truss design drawings shall include, at a minimum, the information specified below:

1. Slope or depth, span and spacing;
2. Location of joints;
3. Required bearing widths;
4. Design loads as applicable;
5. Top chord live load (including snow loads);
6. Top chord dead load;
7. Bottom chord live load;
8. Bottom chord dead load;
9. Concentrated loads and their points of application as applicable;
10. Controlling wind and earthquake loads as applicable;
11. Adjustments to lumber and metal connector plate design value for conditions of use;
12. Each reaction force and direction;
13. Metal connector plate type, size, thickness or gage, and the dimensioned location of each metal connector plate except where symmetrically located relative to the joint interface;
14. Lumber size, species and grade for each member;
15. Connection requirements for:
 - 15.1. Truss to truss;
 - 15.2. Truss ply to ply; and
 - 15.3. Field splices.
16. Calculated deflection ratio and maximum vertical and horizontal deflection for live and total load as applicable;
17. Maximum axial tensile and compression forces in the truss members; and
- 18. Required permanent individual truss member bracing and method per Section 2303.4.1.5, unless a specific truss member permanent bracing plan for the roof or floor structural system is provided by a registered design professional.**

Where required by one of the following, each individual truss design drawing shall bear the seal and signature of the truss designer:

1. Registered design professional; or
2. Building official; or
3. Statutes of the jurisdiction in which the project is to be constructed.

Exceptions:

1. When a cover sheet/truss index sheet combined into a single cover sheet is attached to the set of truss design drawings for the project, the single sheet/truss index sheet is the only document that needs to be signed and sealed within the truss submittal package.

2. When a cover sheet and a truss index sheet are separately provided and attached to the set of truss design drawings for the project, both the cover sheet and the truss index sheet are the only documents that need to be signed and sealed within the truss submittal package.

2303.4.1.3 Truss placement diagram. The truss manufacturer shall provide a truss placement diagram that identifies the proposed location for each individually designated truss and references the corresponding truss design drawing. The truss placement diagram shall be provided as part of the truss submittal package, and with the shipment of trusses delivered to the job site. Truss placement diagrams shall not be required to bear the seal or signature of the truss designer.

Exception: When the truss placement diagram is prepared under the direct supervision of a registered design professional, it is required to be signed and sealed.

2303.4.1.4 Truss submittal package. The truss submittal package shall consist of each individual truss design drawing, the truss placement diagram for the project, the truss member permanent bracing specification and, as applicable, the cover sheet/truss index sheet.

2303.4.1.5 Truss member permanent bracing. Where permanent bracing of truss members is required on the truss design drawings, it shall be accomplished by one of the following methods:

1. The trusses shall be designed so that the buckling of any individual truss member can be resisted internally by the structure (e.g., buckling member T-bracing, L-bracing, etc.) of the individual truss. The truss individual member buckling reinforcement shall be installed as shown on the truss design drawing or on supplemental truss member buckling reinforcement diagrams provided by the truss designer.

2. Permanent bracing shall be installed using standard industry bracing details that conform with generally accepted engineering practice. Individual truss member continuous lateral bracing location(s) shall be shown on the truss design drawing.

2303.4.1.6 Anchorage. All transfer of loads and anchorage of each truss to the supporting structure is the responsibility of the registered design professional.

2303.4.1.7 Alterations to trusses. Truss members and components shall not be cut, notched, drilled, spliced or otherwise altered in any way without written concurrence and approval of a registered design professional. Alterations resulting in the addition of loads to any member (e.g., HVAC equipment, water heater) shall not be permitted without verification that the truss is capable of supporting such additional loading.

2303.4.2 Metal-plate-connected trusses. In addition to Sections 2303.4.1 through 2303.4.1.7, the design, manufacture and quality assurance of metal-plate-connected wood trusses shall be in accordance with TPI 1. Manufactured trusses shall comply with Section 1704.6 as applicable.

View all WTCA Tech Notes at www.sbcindustry.com/kb/technotes.php